

# 隔膜泵

## MD 1

[网站链接](#)

### 产品说明

MD 1隔膜泵是针对非腐蚀性气体的无油抽气的极佳选择，其极限真空可达1.5mbar。和相似比率的双级隔膜泵相比，这款三级泵的结构配合平整的膜片，可提供极佳的抽速，即使接近极限真空亦是如此。MD 1是一款非常安静的泵，它的膜片寿命非常长，有长达几年的测试数据为证。气路由铝和经挑选的塑料制成（膜片有PTFE或FKM材质的，阀是FKM材质的），可广泛的适用于非腐蚀性气体。

### 性能特点

- 无污染的抽气或排气过程
- 抽速大，即使接近极限真空时仍具有很高的抽气速度
- 卓越的极限真空
- 排气安静，振动极低
- 膜片寿命长，驱动系统免维护

## 订购信息

产品名称	额定电源电压 工作频率	电源插头类型	订货号
MD 1	220-230 V   50-60 Hz 100-115 V   50-60 Hz 60 Hz   60 Hz	CEE	20696080
MD 1	220-230 V   50-60 Hz 100-115 V   50-60 Hz 60 Hz   60 Hz	CH, CN	20696081
MD 1	220-230 V   50-60 Hz 100-115 V   50-60 Hz 60 Hz   60 Hz	UK, IN	20696082
MD 1	220-230 V   50-60 Hz 100-115 V   50-60 Hz 60 Hz   60 Hz	US	20696083

## 货品配置

泵体安装完毕, 连接即可使用, 附带说明书

## 配件

- 橡胶真空管 DN 8 mm (20686001)
- 密封圈套装 MD 1, MV 0.5 (20696824)

## 技术指标

50 Hz 最大抽速 (mbar)	1.2 m <sup>3</sup> /h
60 Hz 最大抽速 (cfm)	0.82 cfm
极限真空	1.5 mbar / 1.1 torr
泵头数	4
泵级数	3
的允许环境温度范围 (运行)	10 - 40 °C
的允许环境温度范围 (存放)	-10 - 60 °C
最大出气口压力 (绝对压力)	1.1 bar
进气口连接	DN 6 mm 软管喷嘴接头
出气口连接	消音器 / G1/8"
额定电机功率	0.08 kW
额定转速 50/60 Hz	1500/1800 min <sup>-1</sup>
防护等级	IP 40
尺寸 (长×宽×高)	326 mm x 143 mm x 215 mm
重量	7.3 kg
噪音水平 50 Hz/1500 Upm/62% (VARIO)/1500 Upm (VARIO-SP)/12500 Upm (VACUU·PURE®)	40 dBA
NRTL 标准	是

50 Hz下的抽速曲线

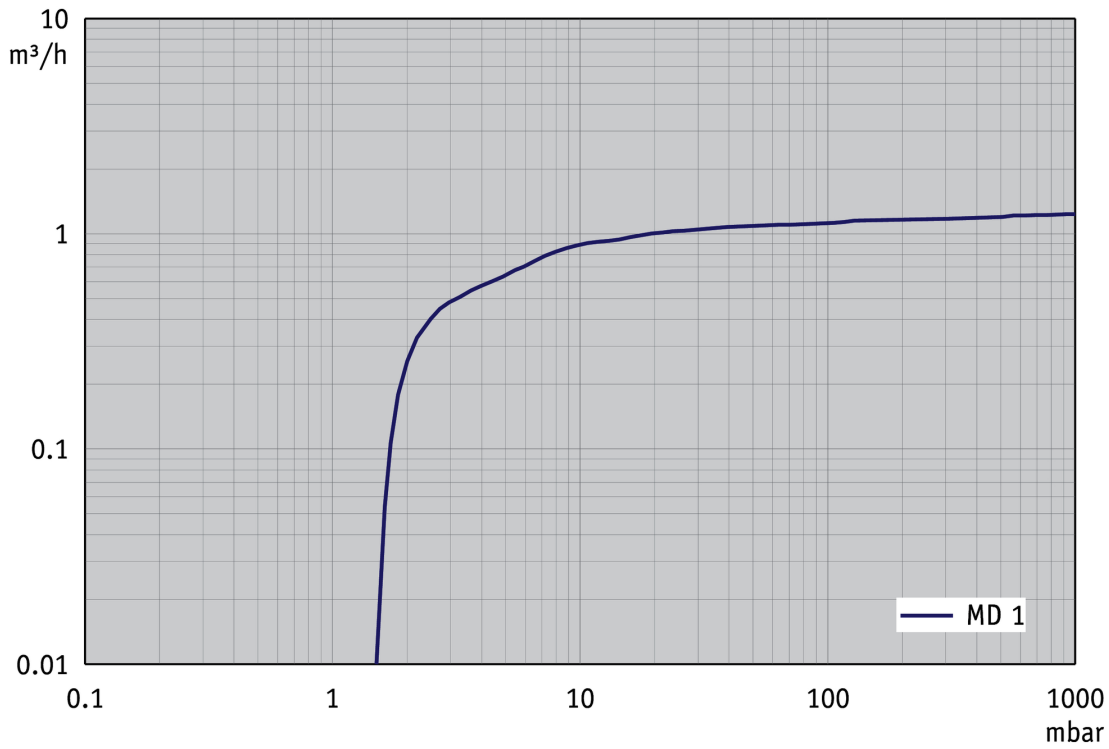

50 Hz下的抽气曲线 (10升容积)

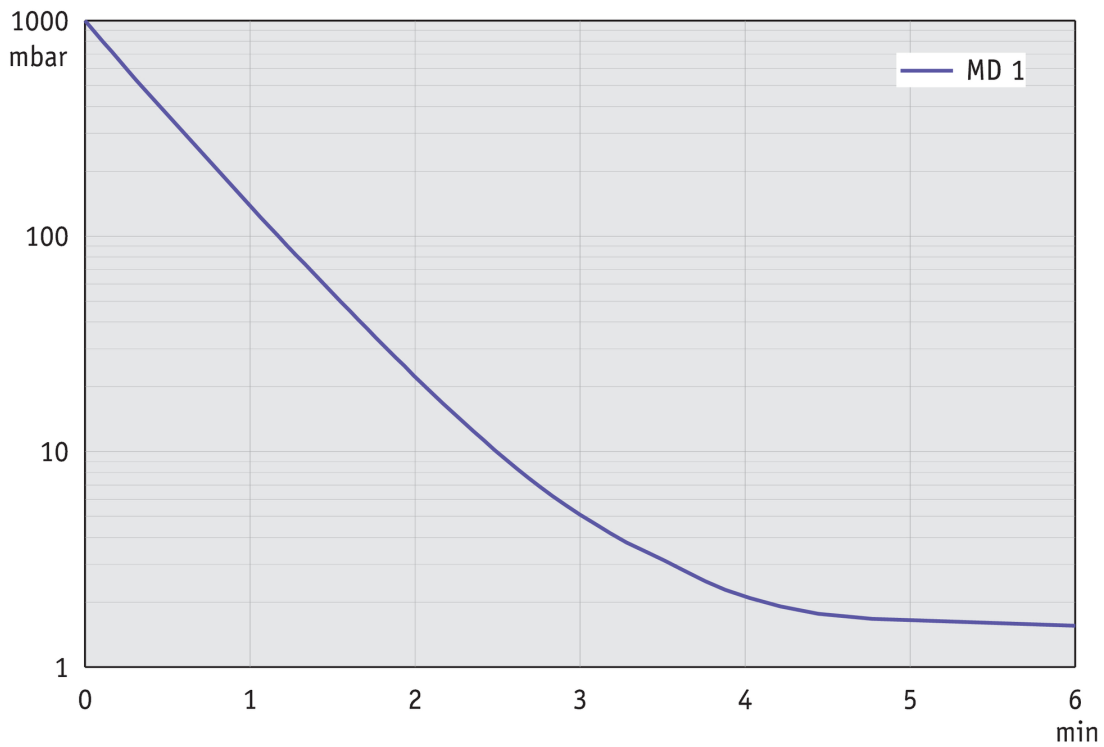

60 Hz下的抽速曲线

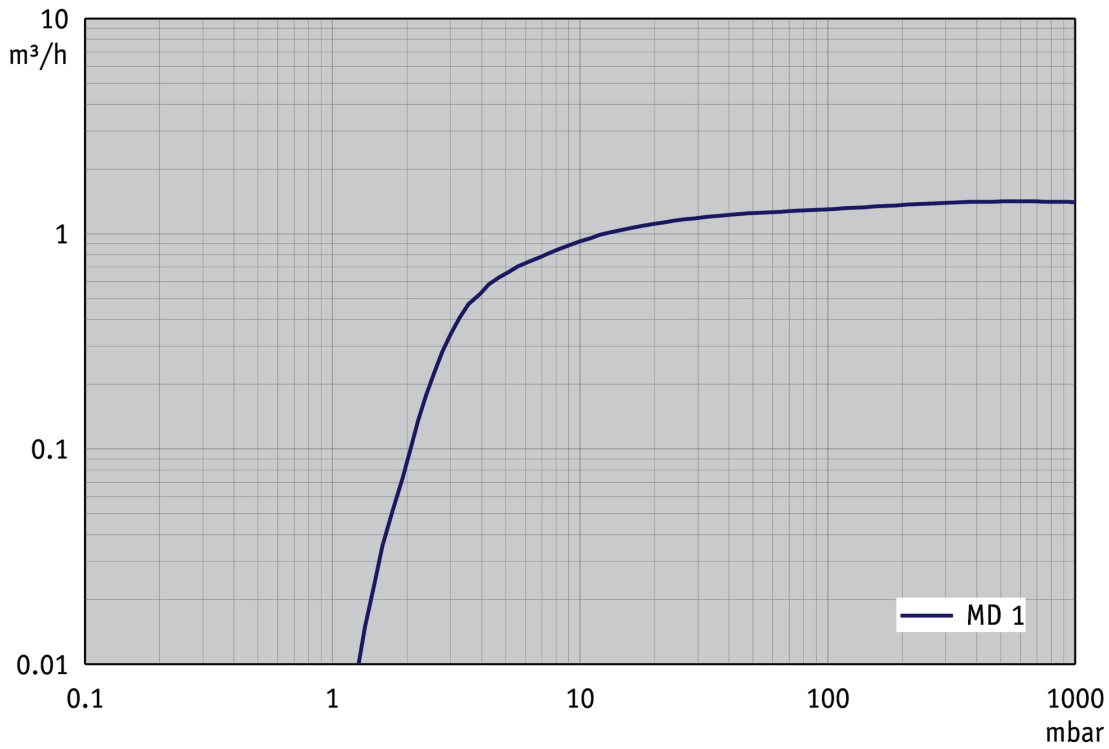

60 Hz下的抽气曲线 (10升容积)

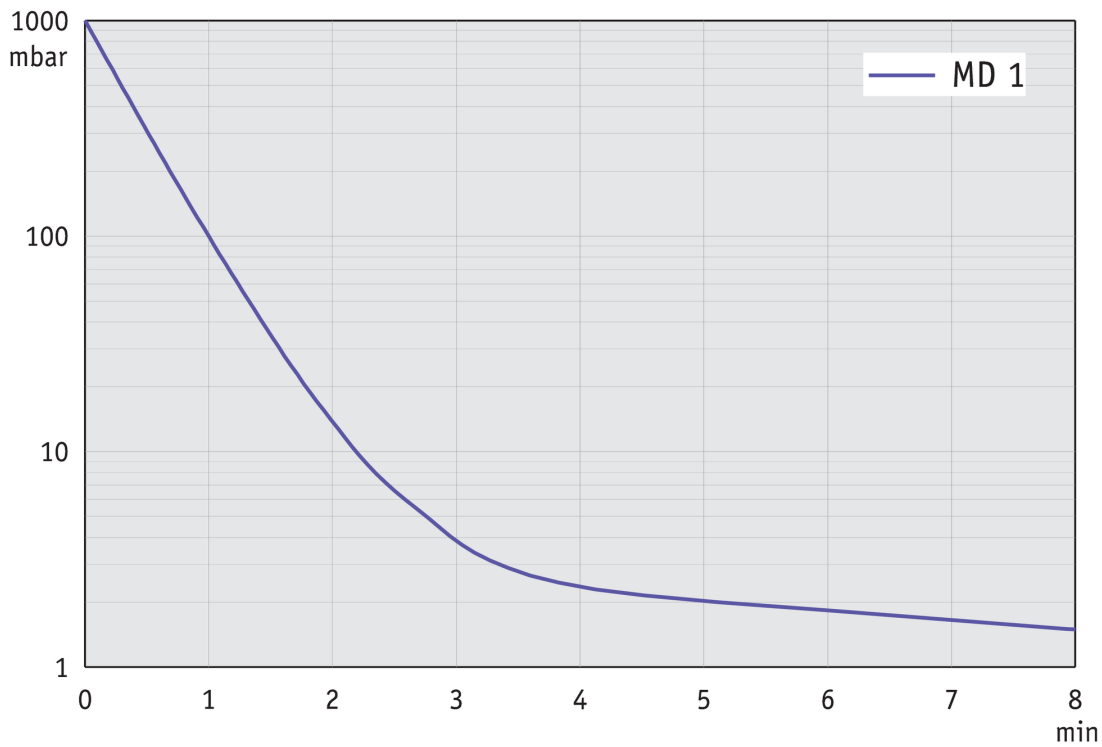

## 尺寸规格表

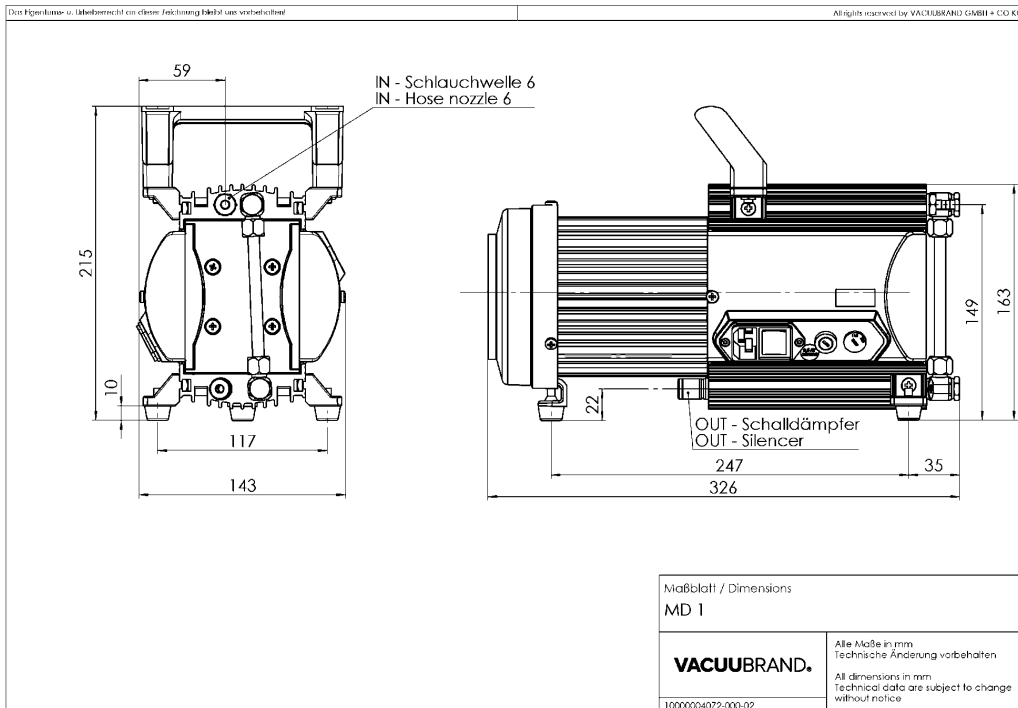

VACUUBRAND GMBH + CO KG  
P.O. Box 1664  
97877 Wertheim  
T +49 9342 808 5550  
F +49 9342 808 5555

info@vacuubrand.com  
www.vacuubrand.com

**VACUUBRAND®**

VACUUBRAND is part of the Brand group, a manufacturer of high-quality and innovative laboratory equipment and vacuum technology with a global team of approx. 1,000 employees.

With highly motivated and qualified employees, we manufacture the world's most comprehensive product family for vacuum generation, measurement and control for the rough and fine vacuum range in the laboratory.

**All with one goal:**

Enabling our customers to run reliable, safe and efficient processes. This is why we commit ourselves to continuous innovation, first-class performance, and outstanding quality.

Engineering excellence is central to our ability to deliver products and solutions renowned for their quality, durability, and reliability. Innovative technology, high quality materials and extensive testing deliver unmatched performance - engineered and manufactured in Germany.

Together with you, our experts will find the best solution for your application and provide you with first-class service along the way.

BRAND (Shanghai) Trading Co., Ltd.  
Shanghai, China

T +86 21 6422 2318  
info@brand.com.cn  
china.brand.com.cn

BRAND Scientific Equipment Pvt. Ltd.  
Mumbai, India

T +91 22 42957790  
customersupport@brand.co.in  
www.brand.co.in

BRANDTECH® Scientific, Inc.  
Essex, CT. United States of America

T +1 860 767 2562  
info@brandtech.com  
www.brandtech.com