

隔膜泵

MD 12 NT VARIO select

[网站链接](#)

产品说明

此款三级隔膜泵是针对非腐蚀性气体持续的、无油抽气的优秀解决方案，拥有极好的极限真空度，能达到1.5mbar。由于它的抽速大，对于高气载应用或要求快速抽气到负压状态的真空箱体，该泵是一个很好的选择。所有沾湿部件均由铝、不锈钢和精心挑选的塑料制成，适用于广泛的无腐蚀性气体应用。MD 12 NT VARIO select可自动调节其电机转速，以保持所需的真空度。这意味着泵运行时非常安静，振动超低，并具有较好的密封性。高柔性纤维增强双FKM膜片是延长泵使用寿命的理想选择。VARIO设计包括变频泵和带外置传感器的VACUU-SELECT真空控制器。VARIO型号按需响应的电机转速控制进一步延长了隔膜和阀门已经很长的使用寿命。而且无油运行意味着没有回流污染的风险。

性能特点

- 配置图形用户界面及预定义应用的VACUU-SELECT真空控制器能简化实验室工作
- 超长的膜片寿命，维护周期长且维护成本低
- 无污染泵抽及排放
- 高抽气速度，优异的极限真空，在TURBO模式下可作为涡轮分子泵的前级泵

订购信息

产品名称	额定电源电压 工作频率	电源插头类型	订货号
MD 12 NT VARIO select	200-230 V 50-60 Hz	CEE	25743150
MD 12 NT VARIO select	100-120 V 50-60 Hz	US	25743153

货品配置

泵体安装完毕，连接即可使用，消音器，附带说明书

配件

- VACUU-SELECT用户管理 VACUU-SELECT User Management (20700900)
- 小法兰的中心支架 KF DN 20/25 (20660001)
- 小法兰外齐式环形中心支架 KF DN 20/25 (20660196)
- PVC真空管，内置不锈钢螺线，带小法兰 KF DN 25 (20686021)
- 带软管喷嘴接头的小法兰 KF DN 25 / DN 10 mm (20662807)
- 橡胶真空管 DN 10 mm (20686002)
- 进气阀 VB M-B (20674217)
- 密封圈套装 MV 10 / MD 12 (20696827)

技术指标

50 Hz 最大抽速 (mbar)	13.4 m ³ /h
60 Hz 最大抽速 (cfm)	7.9 cfm
极限真空	1.5 mbar / 1.1 torr
泵头数	8
泵级数	3
真空控制器	VACUU·SELECT
的允许环境温度范围 (运行)	10 - 40 °C
的允许环境温度范围 (存放)	-10 - 60 °C
最大出气口压力 (绝对压力)	1.1 bar
进气口连接	KF DN 25 小法兰
出气口连接	G1/2"
额定电机功率	0.53 kW
电机转速范围	30 - 2400 min ⁻¹
防护等级	IP 40
尺寸 (长x宽x高)	552 mm x 260 mm x 450 mm
重量	31.6 kg
噪音水平 50 Hz/1500 Upm/62% (VARIO)/1500 Upm (VARIO-SP)/12500 Upm (VACUU·PURE®)	50 dBA
NRTL 标准	否
通讯	Ethernet (RJ45): Modbus TCP / USB (Type A): Data transfer, software update, RS-232 (additional adapter required)

50 Hz下的抽速曲线

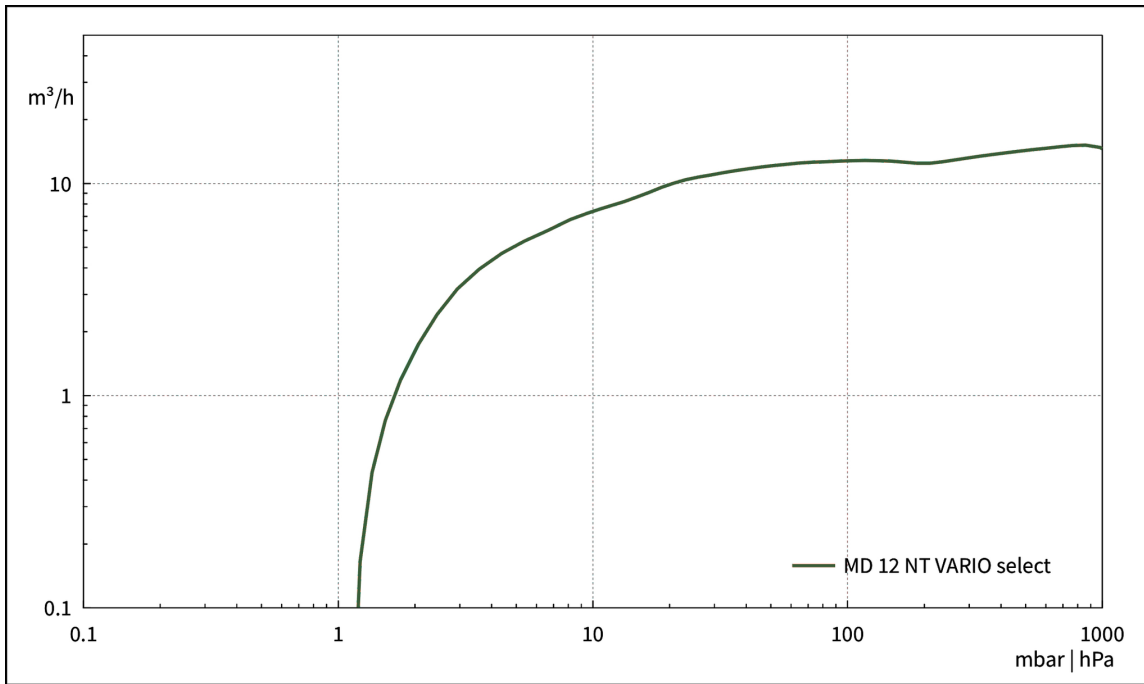

50 Hz下的抽气曲线 (100升容积)

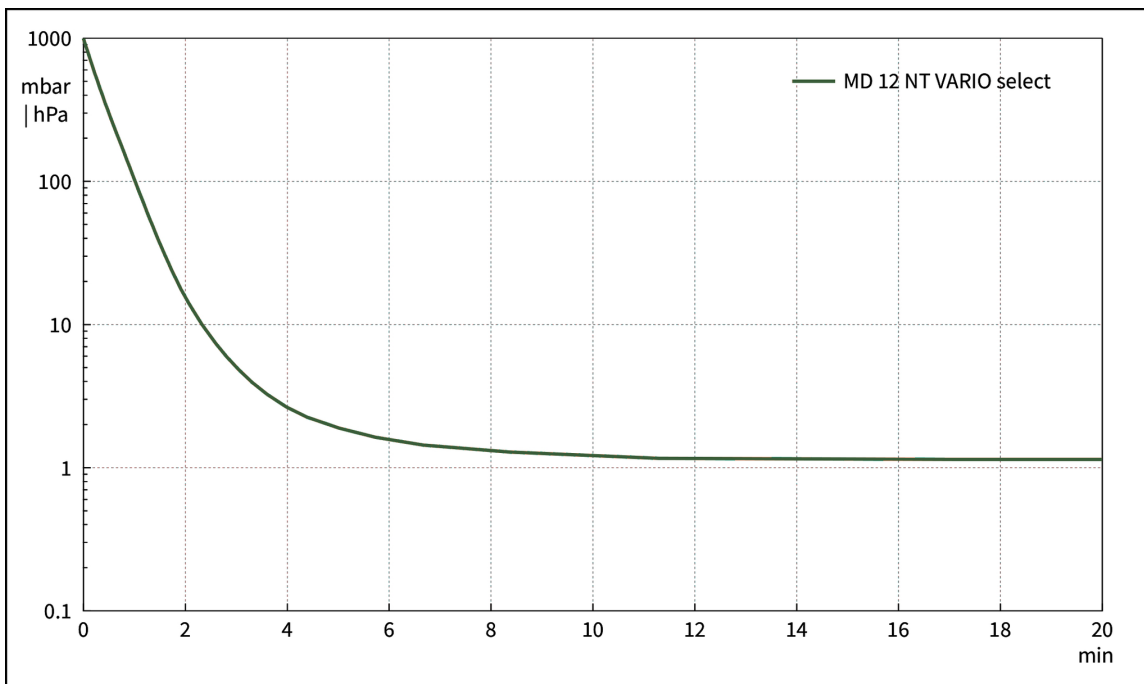

尺寸规格表

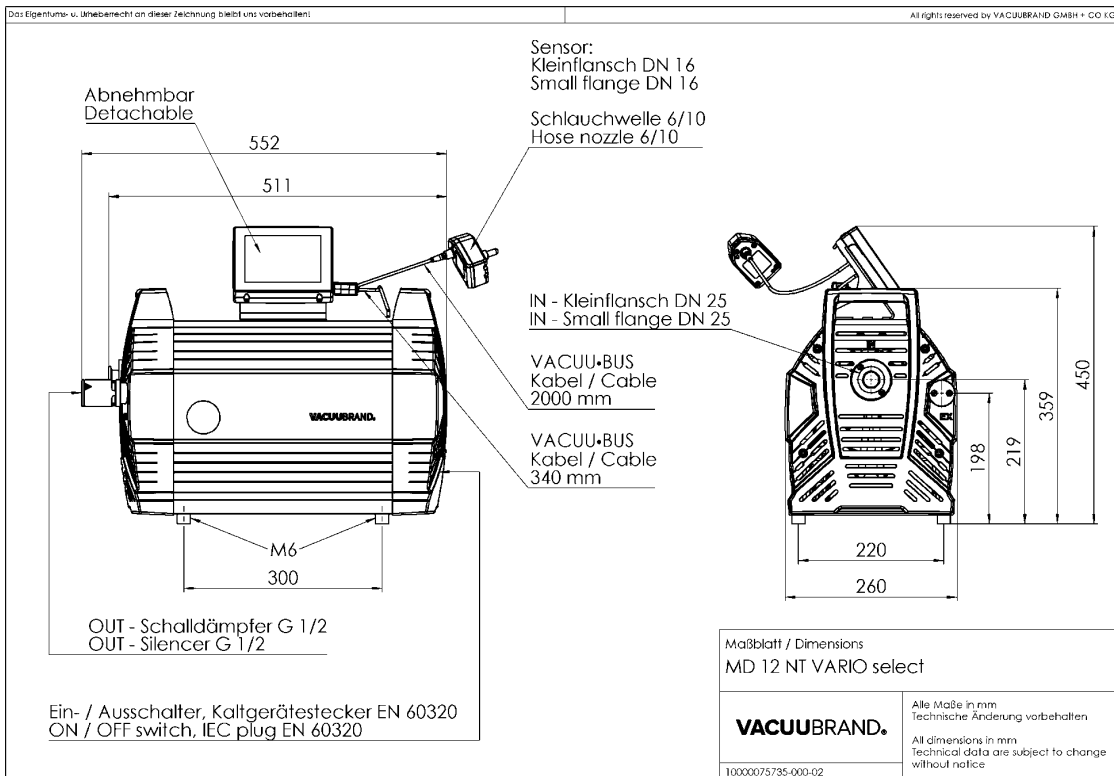

VACUUBRAND GMBH + CO KG
P.O. Box 1664
97877 Wertheim
T +49 9342 808 5550
F +49 9342 808 5555

info@vacuubrand.com
www.vacuubrand.com

VACUUBRAND®

VACUUBRAND is part of the Brand group, a manufacturer of high-quality and innovative laboratory equipment and vacuum technology with a global team of approx. 1,000 employees.

With highly motivated and qualified employees, we manufacture the world's most comprehensive product family for vacuum generation, measurement and control for the rough and fine vacuum range in the laboratory.

All with one goal:

Enabling our customers to run reliable, safe and efficient processes. This is why we commit ourselves to continuous innovation, first-class performance, and outstanding quality.

Engineering excellence is central to our ability to deliver products and solutions renowned for their quality, durability, and reliability. Innovative technology, high quality materials and extensive testing deliver unmatched performance - engineered and manufactured in Germany.

Together with you, our experts will find the best solution for your application and provide you with first-class service along the way.

BRAND (Shanghai) Trading Co., Ltd.
Shanghai, China

T +86 21 6422 2318
info@brand.com.cn
china.brand.com.cn

BRAND Scientific Equipment Pvt. Ltd.
Mumbai, India

T +91 22 42957790
customersupport@brand.co.in
www.brand.co.in

BRANDTECH® Scientific, Inc.
Essex, CT. United States of America

T +1 860 767 2562
info@brandtech.com
www.brandtech.com