

Diaphragm pump MV 2 NT

[Link to the website](#)



Product description

Four-stage diaphragm pumps are an excellent solution for continuous, oil-free pumping of gases when the need is to reach fractional millibar ultimate vacuums. All parts in contact with pumped vapors or gases are made of aluminum, stainless steel and carefully selected plastics suitable for a wide range of non-corrosive applications. The new NT-series pumps provide whisper-quiet and ultra-low-vibration operation, high leak-tightness and improved vacuum. The highly flexible, fabric-reinforced double diaphragm made of FKM offers extended operating life.

Performance features

- contamination-free pumping and evacuation
- high flow rate even near ultimate vacuum
- outstanding ultimate vacuum
- whisper quiet and ultra-low vibration
- exceptionally long diaphragm life and maintenance-free drive system for low lifetime costs

Ordering data

Product name	Nominal mains voltage mains frequency	Plug type	Articleno.
MV 2 NT	230 V 50-60 Hz	CEE	20738000
MV 2 NT	230 V 50-60 Hz	CH, CN	20738001
MV 2 NT	230 V 50-60 Hz	UK, IN	20738002
MV 2 NT	100-115 V 50-60 Hz 120 V 60 Hz	US	20738003

Items supplied

Pump completely mounted, ready for use, with manual.

Accessories

- Vacuum tubing transparent DN 8 mm (20686061)
- Clamping ring for small flange KF DN 10/16 (20660000)
- External centring ring for small flange KF DN 10/16 (20660190)
- Small flange with hose nozzle KF DN 16 / DN 10 mm (20662806)
- Set of diaphragms and valves MD 4 NT / MV 2 NT / MD 4 NT VARIO / MV 2 NT VARIO (20696861)

Technical data

Max. pumping speed 50 Hz (mbar)	2.2 m ³ /h
Max. pumping speed 60 Hz (cfm)	1.4 cfm
Ultimate vacuum	0.5 mbar / 0.4 torr
Number of heads	4
Number of stages	4
Permissible ambient temperature range (operation)	10 - 40 °C
Permissible ambient temperature range (storage)	-10 - 60 °C
Max. outlet pressure (abs.)	1.1 bar
Inlet connection	small flange KF DN 16
Outlet connection	Silencer / G1/4"
Rated motor power	0.25 kW
Rated speed 50/60 Hz	1500/1800 min ⁻¹
Protection class IEC 60529	IP 40
Dimensions (L x W x H)	328 mm x 239 mm x 198 mm
Weight	16.4 kg
Noise (sound pressure level) in dBA at 50 Hz or 1500 rpm/62% (VARIO)/1500 rpm (VARIO-SP)/12500 Upm (VACUU·PURE®)	50 dBA
ATEX conformity	II 3/- G Ex h IIC T3 Gc X Internal Atm. only
NRTL certification	Yes

Pumping speed graph at 50 Hz

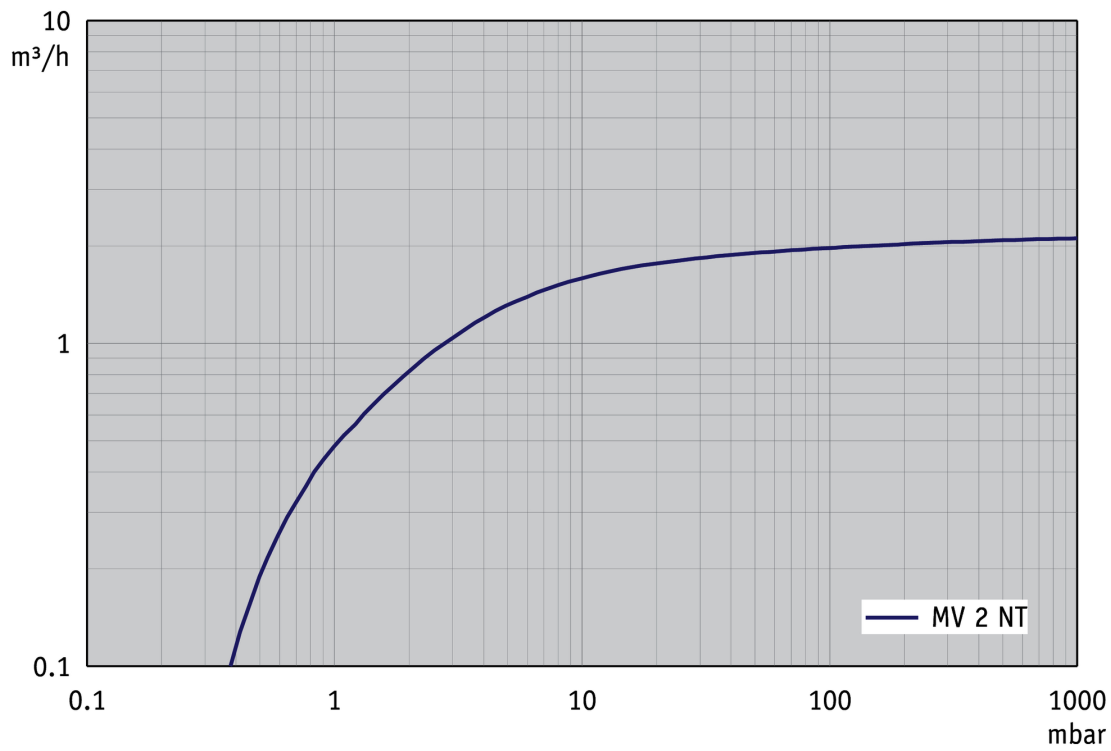

Pump down graph at 50 Hz (10 l volume)

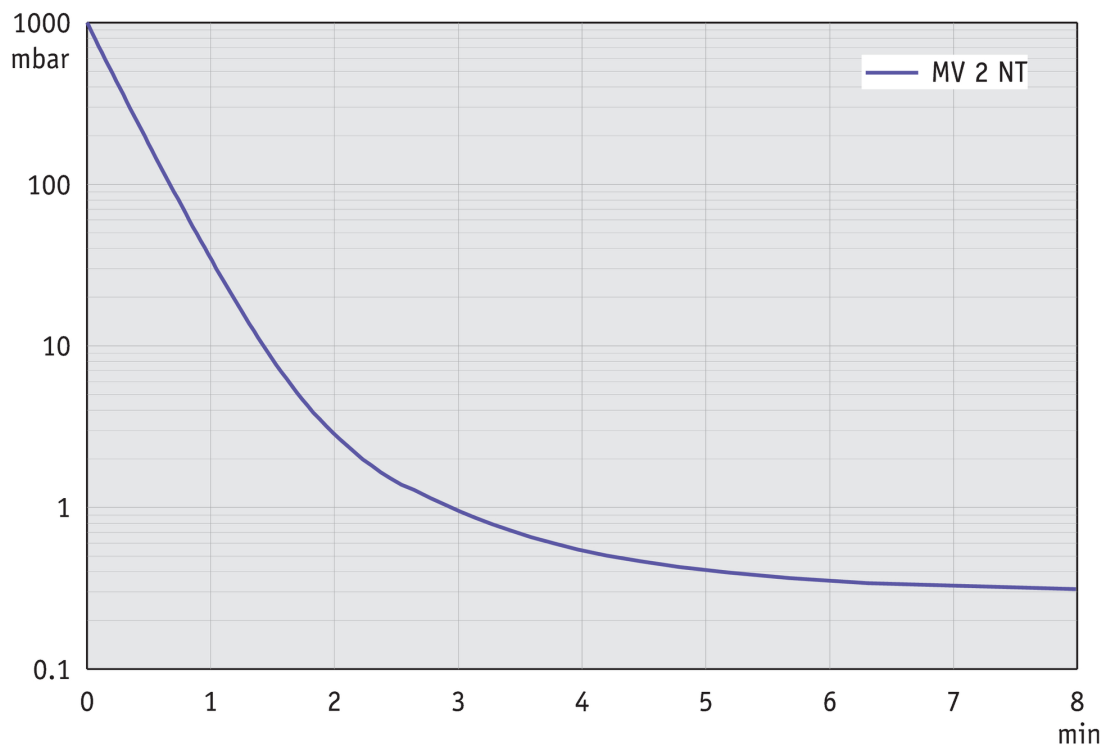

Pumping speed graph at 60 Hz

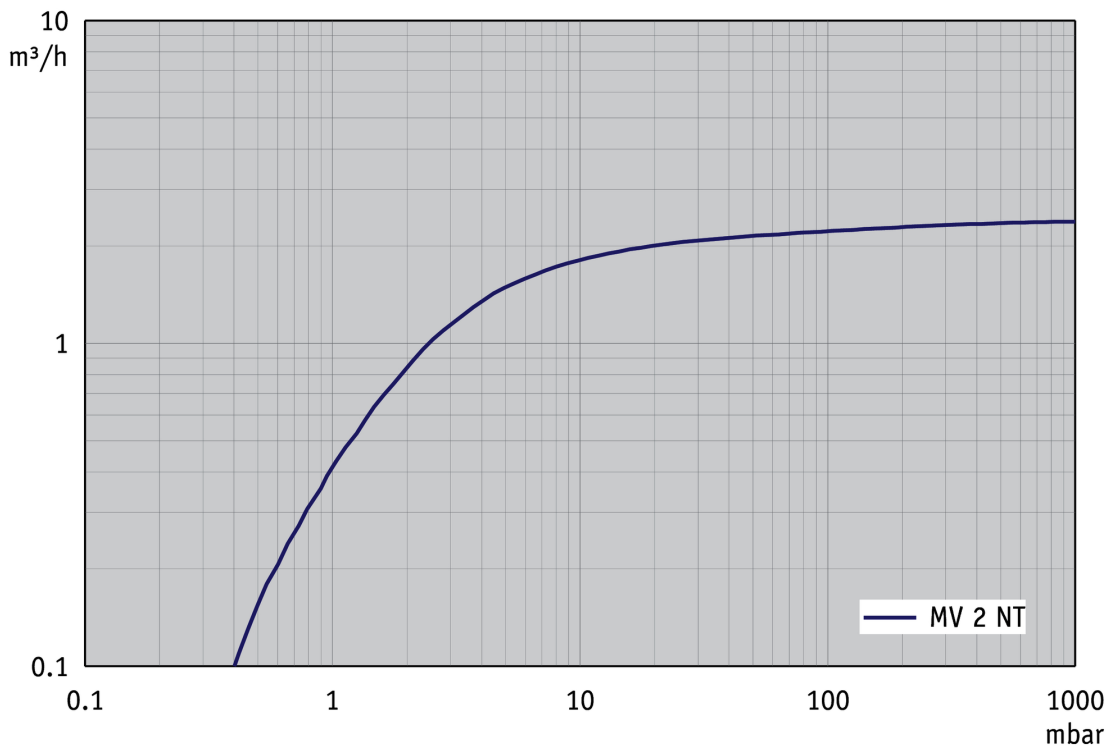

Pump down graph at 60 Hz (10 l volume)

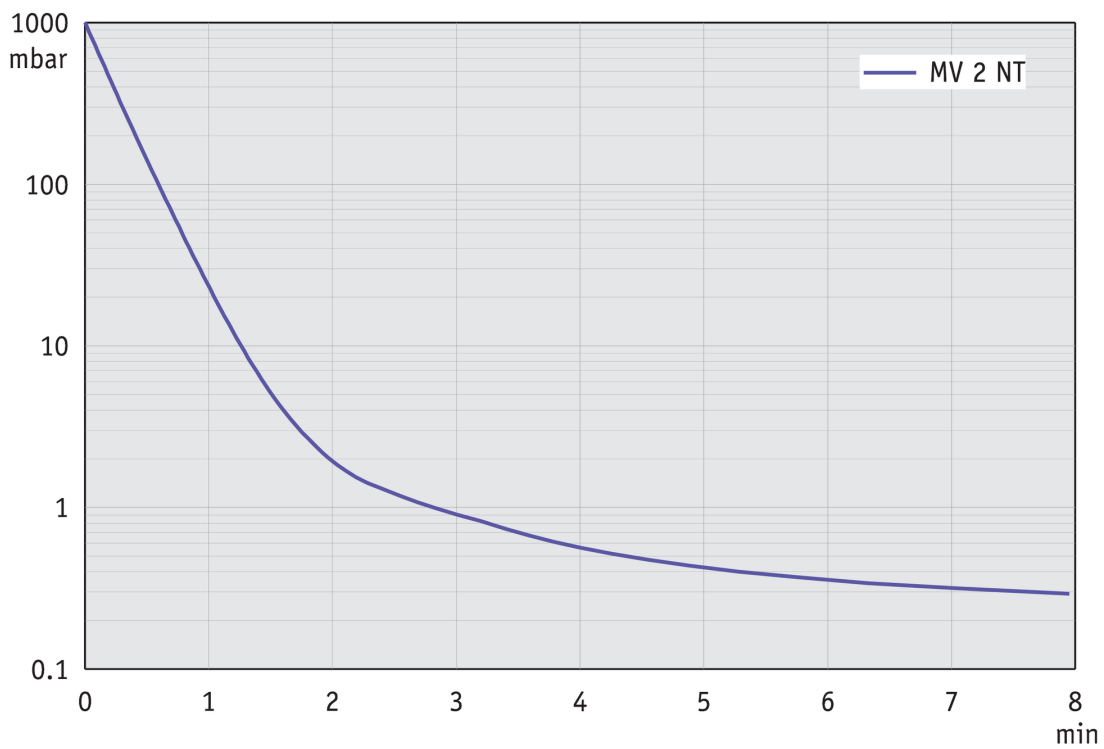

Dimension sheet

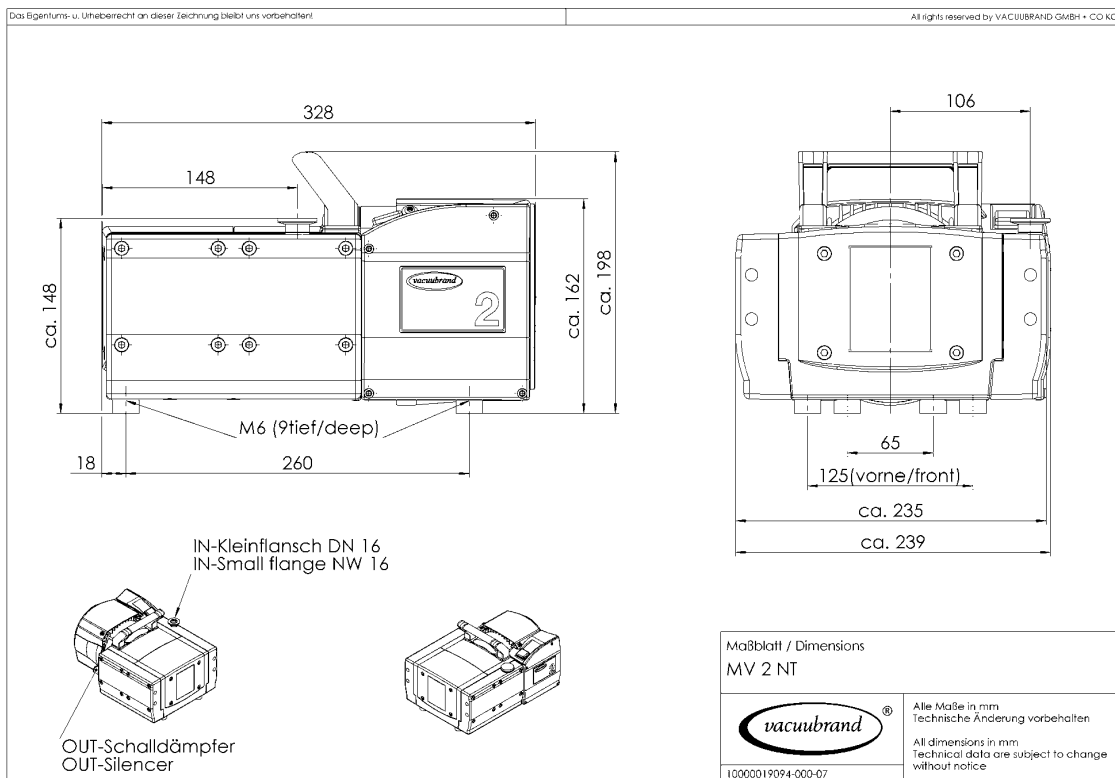

VACUUBRAND GMBH + CO KG
P.O. Box 1664
97877 Wertheim
T +49 9342 808 5550
F +49 9342 808 5555

info@vacuubrand.com
www.vacuubrand.com

VACUUBRAND®

VACUUBRAND is part of the Brand group, a manufacturer of high-quality and innovative laboratory equipment and vacuum technology with a global team of approx. 1,000 employees.

With highly motivated and qualified employees, we manufacture the world's most comprehensive product family for vacuum generation, measurement and control for the rough and fine vacuum range in the laboratory.

All with one goal:

Enabling our customers to run reliable, safe and efficient processes. This is why we commit ourselves to continuous innovation, first-class performance, and outstanding quality.

Engineering excellence is central to our ability to deliver products and solutions renowned for their quality, durability, and reliability. Innovative technology, high quality materials and extensive testing deliver unmatched performance - engineered and manufactured in Germany.

Together with you, our experts will find the best solution for your application and provide you with first-class service along the way.

BRAND (Shanghai) Trading Co., Ltd.
Shanghai, China

T +86 21 6422 2318
info@brand.com.cn
china.brand.com.cn

BRAND Scientific Equipment Pvt. Ltd.
Mumbai, India

T +91 22 42957790
customersupport@brand.co.in
www.brand.co.in

BRANDTECH® Scientific, Inc.
Essex, CT. United States of America

T +1 860 767 2562
info@brandtech.com
www.brandtech.com